

JETTUNNEL[™]

DRYING & BLOWOFF SYSTEM

The JetTunnel[™] is a drying system which is easy to install, captures overspray, and has an industry low dba rating for the consumer-package-goods market.

It achieves superior dryness prior to labeling, inspection, coding, sleeving, secondary packaging, and more. The JetTunnel[™] is powered by JetAir's high-speed centrifugal blowers, which deliver clean, oil-free, filtered air to remove unwanted moisture and debris. The JetTunnel[™] is custom designed to handle the widest range of containers and line speeds up to 120,000 cph. It easily integrates into existing packaging lines and all plant control networks. Standard and custom systems are available.



SYSTEM HIGHLIGHTS

- High speed, energy efficient DirectDrive™ blower housed in integrated wash-down chamber
 - Blower is optimized for higher kW efficiency & reduced footprint
 - Blower has no belt and is tensioner-free
- Customized to line speed and container sizes
- Application-specific air components
- Coalescing inlet air filter (HEPA available)
- JetSet™ mounts for fast and repeatable changeovers
- Custom guide rails included

CONTROLS

- Allen-Bradley Variable Frequency Drive standard (all VFD brands available)
- LOTO line power fused disconnect
- Operator-friendly interface & system status indicators
- UL508, cUL, CE standards
 - CAT 3-4/PLd-e available
- OMAC PackML compliant
- Electrical Panel NEMA4/IP66

MAINTENANCE

- Interior designed for water collection & removal
- Washdown Stainless Steel 304
 - SS316 & CPVC solutions available
- Double-walled construction for low noise
 - Sound attenuation (78-87dB)
- Removable, sloped drip pan for water capture & fast cleaning
- Lift-off panel for easy maintenance
- Heavy-duty door with large vision window for conveyor & air component access
- Stainless steel threaded levelers for 5" vertical adjustment
- Integrated lifting eyes for easy installation
- Minimal spare parts



Standard Dimensions:

CONVEYOR:
TOC: up to 48" Width: up to 6" Height: up to 9"
PRODUCT:
Diameter: up to 5.75"
Height: 6.75 to 11.75"

Customization for other dimensions available.

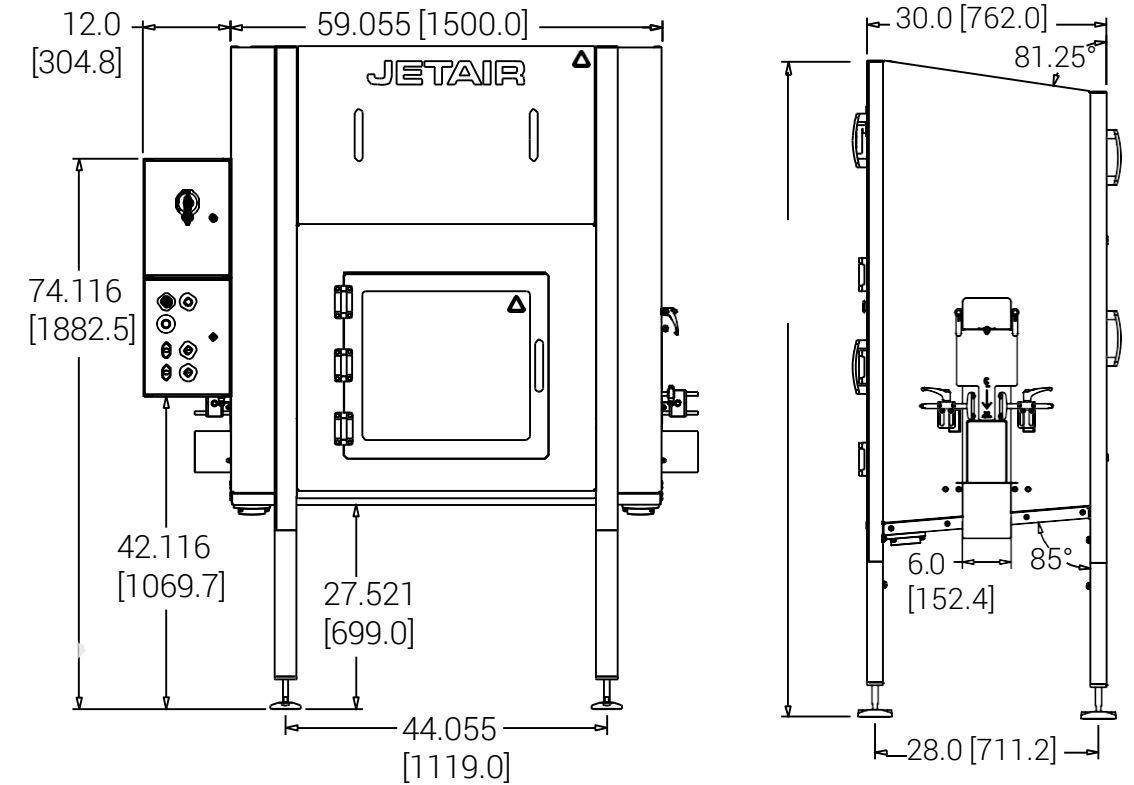

Optional Features

- Network integration
 - Ethernet, Profibus, DeviceNet
- Integrated transport conveyor
- Container hold-down
- Clean In Place (CIP)
- Water rinse & drying
- Emergency glass shard protection
- Door interlocks
- Product detection sensor
- JetSet™ automatic multi-point adjustment changeover

ABOUT JETAIR

FROM BLOWERS TO CUSTOM SOLUTIONS

JetAir has evolved to create custom engineered solutions. Starting with a technically advanced direct drive blower, Jet air has evolved to develop market driven solutions such as our very own high velocity jet blast air knives, spray shields, sound enclosures, all in one turnkey systems, to complete engineered to order solutions.

Our team is committed to creating accelerated solutions using air by providing safe, easy-to-use, innovative equipment. JetAir creates machines with improved performance, a smaller footprint, network integration, and reduced power consumption.

JetAir has many turnkey solutions and combined with our ability to design custom equipment –we build the ultimate drying machine.

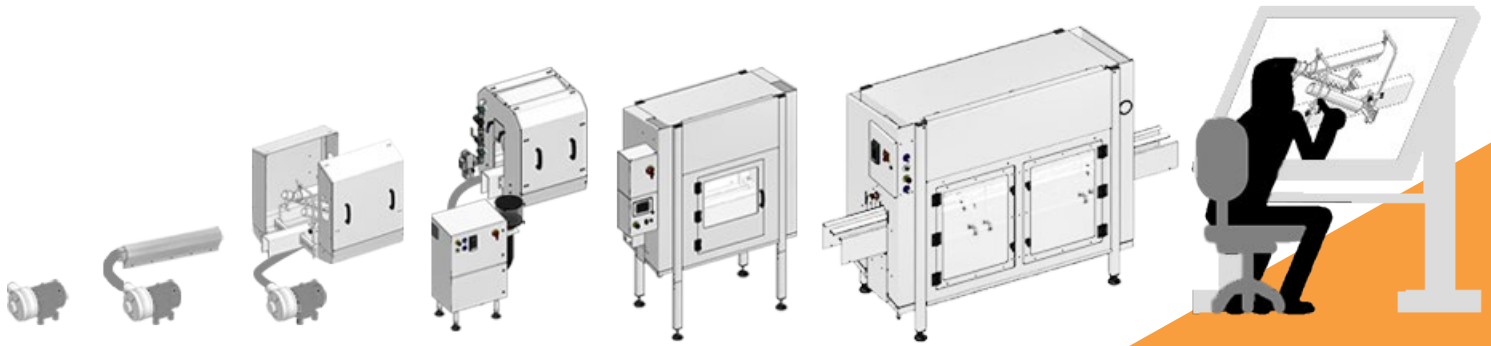

Installation & Spare Parts Worldwide
2018 JetAir Technologies, LLC

1756 Eastman Ave. #100 Ventura, CA 93003 USA
sales@jetairtech.com | (805) 654-700 | www.jetairtech.com