

# SURECODE™

## DRYING & PRINTING SYSTEM

**The SureCode™ delivers precise, reliable coding in the smallest footprint.**

The SureCode™ brings top-tier drying equipment together with state-of-the-art printing technology, ensuring your codes are pristine. Product flows through an integrated drying/blow-off chamber, removing any water and debris prior to printing for clear, legible, and reliable codes. Using JetAir's high-speed, high-efficiency blower and Domino's Ax-Series continuous inkjet technology, this system has built-in quality assurance. The SureCode™ is custom designed to handle the widest range of containers and line speeds up to 2,975 cpm. It easily integrates into existing packaging lines and all plant control networks. Standard and custom systems are available.



WITHOUT THE SURECODE™



WITH THE SURECODE™



**DRYER HIGHLIGHTS**

- Drying delivered by high speed, energy efficient blower in wash-down chamber
  - Blower is optimized for higher kW efficiency & reduced footprint
  - Blower is belt and tensioner free
- Customized to line speed and container sizes & geometries
- Includes application-specific air components, coalescing inlet air filter (HEPA available), and mounts for fast and repeatable changeovers

**PRINTER HIGHLIGHTS**

- Delivers continuous, high-speed, rapid-throughput inkjet printing
- i-Pulse™ print heads and ink generate precision ink drops for high resolution printing
  - Single Nozzle or DUO i-Pulse™ Printheads available
  - 9 drop quality at 7 drop speeds
  - Inks for the toughest substrates
- Machine Vision readable codes for label verification applications
- Metal food can coding for all retort sterilization processes
- High-quality codes are optimized to reduce rejects
- Integration into most factory automation line control systems

**CONTROLS**

- Smooth line integration
- Allen-Bradley Variable Frequency Drive standard (all VFD brands available)
- Intuitive operator-friendly interface & system status indicators
- UL508, cUL, CE standards
  - CAT 3-4/PLd-e available
- OMAC PackML compliant
- Electrical Panel NEMA4/IP66
- Optional controls available (see next page)

**MAINTENANCE**

- Interior designed for water collection & removal
- Washdown Stainless Steel 304
  - SS316 & CPVC solutions available
- Double-walled construction for low noise
  - Sound attenuation (78-85dB)
- Removable, sloped drip pan for water capture & fast cleaning
- Lift-off panel for easy maintenance
- Heavy-duty door with large vision window for conveyor & air component access
- Stainless steel threaded levelers for 5" vertical adjustment
- Integrated lifting eyes for easy installation
- Minimal spare parts



inches[mm]

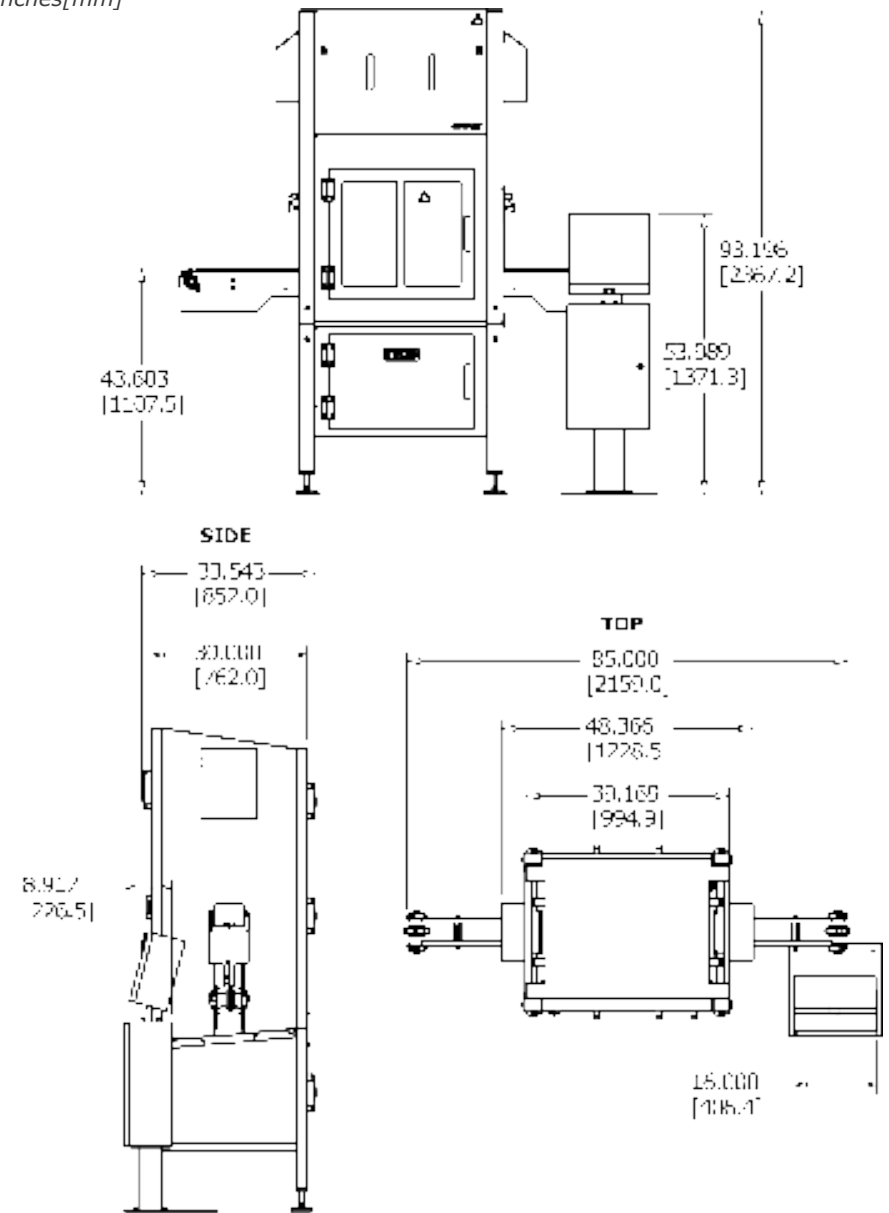

**Optional Features**

- Network integration: Ethernet, Profibus, DeviceNet
- Domino QuickDesign coding automation & message design software
- Integrated transport conveyor
- Emergency glass shard protection
- Container hold-down
- Clean In Place (CIP)
- JetSet™ automatic multi-point adjustment changeover
- Water rinse & drying
- Door interlocks
- Code quality detection sensor



**SURECODE™ Control Options**

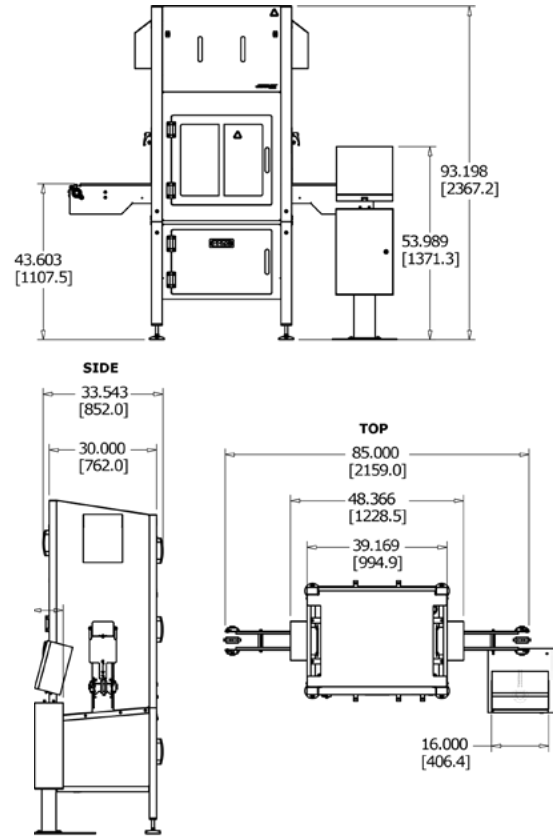

**Onboard Controls**  
An economic option that separates push button drying function and full printing capabilities using a Domino-designed HMI.

